

Power Star LW/LWS

Product Information Guide

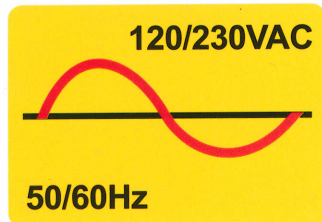

1000W	5000W
2000W	6000W
3000W	7000W
4000W	8000W

Continuous power
with P.F.C charger

Sine Wave Combined Inverter & Charger



Models: LW1000-12-C, LW1000-24-C, LW1500-12-C, LW1500-24-C, LW2000-12-C
LW2000-24-C, LW3000-12-C, LW3000-24-C, LW3000-48-C, LW4000-24-C
LW4000-48-C, LW5000-24-C, LW5000-48-C, LW6000-24-C, LW6000-48-C
LW7000-48-C, LW7000-72-C, LW8000-48-C, LW8000-72-C
LWS1000-12-C, LWS1000-24-C, LWS1500-12-C, LWS1500-24-C, LWS2000-12-C
LWS2000-24-C, LWS3000-12-C, LWS3000-24-C, LWS3000-48-C, LWS4000-24-C
LWS4000-48-C, LWS5000-24-C, LWS5000-48-C, LWS6000-24-C, LWS6000-48-C
LWS7000-48-C, LWS7000-72-C, LWS8000-48-C, LWS8000-72-C



Combined Inverter & Charger

Basic wiring for the Power Star LW/LWS Series

Warning: High voltage, do not open unless qualified to do so; Please read instructions before working on this product.

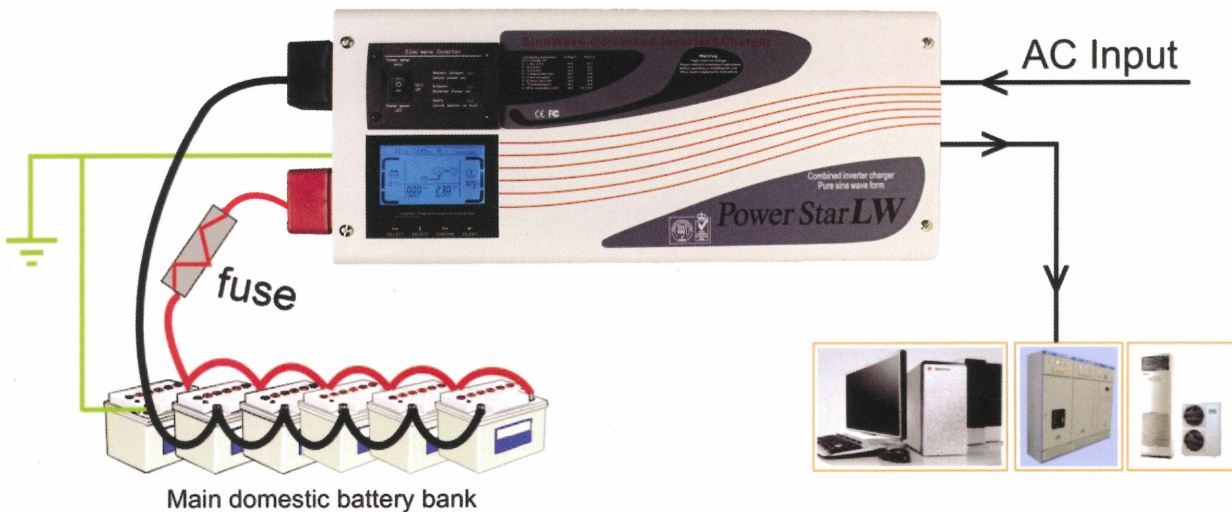

WHAT CABLE TO USE in mm²

A charger or inverter	Cable ryn distance 0-1.5m	Cable ryn distance 1.5-4.0m
0-150A	25mm ²	35mm ²
150-200A	50mm ²	70mm ²
200-350A	70mm ²	90mm ²

Please note that if there is a problem obtaining, for example 90 mm² cable, use 2*50 mm², or 3*35 mm². To adopt one cable is always the best, cable is simply copper and all require ins the copper, so it does not matter if it is one cable for ten cables as long as the square areas adds up. Performance of any products can be improved by thicker cable and shorter runs, so if just keep the length as short as possible.

natural earth inverter requirements
if you what to maintain a trough earth simply connect the input earth to the output earth.

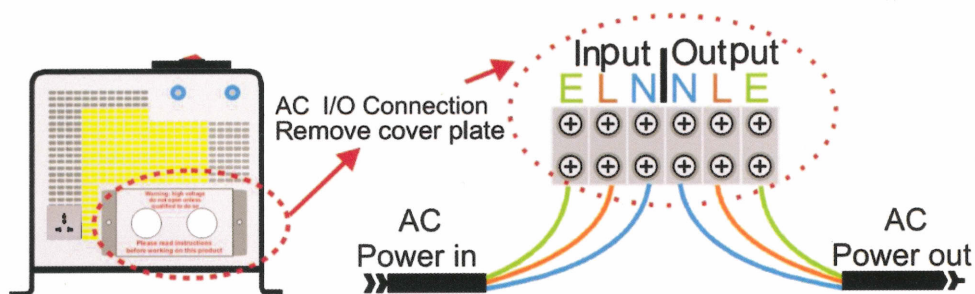
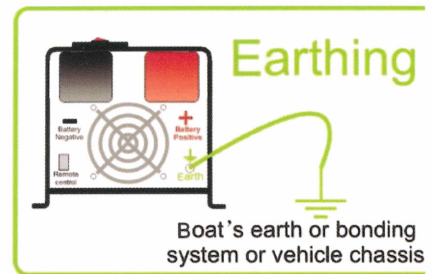

Check list

- 1) Ensure that the inverter has the correct DC voltage for your boat or vehicle system. ie 12 or 24V/48V/72V.
- 2) Fit as close to the batteries as possible, the shorter the DC cables the better. Voltage drop on long cables will effect the unit's performance.
- 3) Do not reverse the cables! Connect the red cable to the positive terminal and the black cable to the negative terminal of the battery. In the event of reverse polarity the unit could be totally destroyed.
- 4) Always use the inverter in an environment which is well ventilated, not exposed to direct sunlight or a heat source, away from water, moisture, oil or grease, away from any highly inflammable substance, out of reach from children.
- 5) The output voltage of this unit must never be on your AC system at the same time as any other AC source such as the 230V external mains line or a generator. All external power must go through the Power Star LW.
- 6) Always switch on the Power Star LW, before plugging in any appliance.
- 7) Under new electrical legation only professional electrocutions should install the product. Ensure the fitting instructions are fully understood before fitting this product.

Installation

- 1) Position the unit as close to the main battery bank as possible
- 2) Position in a cool, dry & well ventilated space.
- 3) Orientation of the unit is not critical.
- 4) Either purchase the standard cable set from Dealer which is about 1.5 meters, or if using your own cable, use the cable size chart provided on the installation drawing to ensure you have thick enough cable for the DC leads. In the event of not being able to get the size requested (it can be hard to get thick cable) then simply add multiple length of thinner cable, i.e. if you cannot get 90 mm² cable then use 3*35 mm² cable.
- 5) Fit a fuse suitable for the job, again look at the installation drawing. We have a full range of high current fuses in the GANLR range of gold fuse products, ranging form 100-500 Amp.on the DC side
- 6) Connect the cables from the batteries to the fuse then to the unit, this way if there is a fault at the unit the fuse is already in place and this will be safe. In the event of a isolation switch being used, please ensure the rating of the switch can handle the power of the unit.
- 7) Ensure the unit is switched off during installation.
- 8) On the AC side ensure the shore power (all external AC sources) are totally disconnected, connect the output from the inverter to suitable Residual Current Breaker (R.C.D for the earth protection) and current over load trips Fuse the AC input side depending on through power requirements, the max through power is 30Amp Ps,so fuse at 40A(allowing also for charger consumption) if you intend to use the full through power for standard 1316 amps throughput then a 20A fuse would be appropriate.
- 9) We recommend Multi core tri rated AC cable, if used on a boat or vehicle, as this is much safer where vibration is likely. Only use single solid household AC cable if the product is being used as a power source for a house or platform free of vibration.
- 10) Before attempting to switch on the unit, please ensure you have selected the correct battery type on the small battery type selector switch on the front of the main box, rotate the switch to your battery types. The progressive charge control software will automatically adjusted for battery bank size and state

Charge Stage Transition Definitions

- Boost CC Stage: If AC input is applied, the charger will run at full current in CC mode until the charger reaches the boost voltage.
- Software timer will measure the time from AC start until the battery charger reaches 0.3V below the boost voltage, then take this time as T_0 and $T_0 * 10 = T_1$.
- Boost CV Stage: Start a T_1 . Timer; the charger will keep the boost voltage in Boost CV mode until the T_1 . Timer has run out. The drop the voltage down to the float voltage. The timer has minimum time of 1 hour and a maximum time of 12 hours.
- Float Stage: In float mode, the voltage will stay at the float voltage.
- If the AC is reconnected or the battery voltage drops below 12Vdc/24Vdc, the charger will reset the cycle above.
- If the charge maintains the float state for 10days, the charger will reset the cycle.

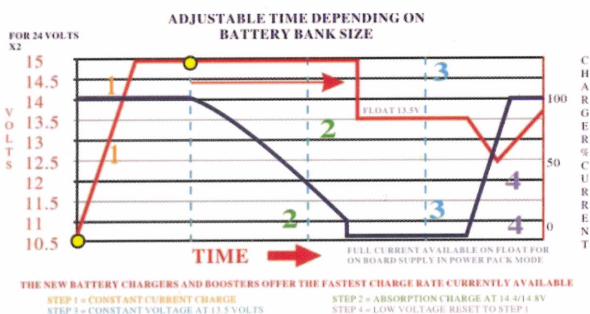

The battery type and charge voltage recommendations are set out above For 24V unit x the above by

2. Some battery types may look confusing such as GEL USA and GEL EURO, AGM USA and AGM EURO. If you find this confusion then join the club, we have had the different voltage curves supplied to us by different companies form the U.S.A. and Europe for what we seem the same product, however it's not our call, we simply supply the options, if in doubt call your battery supplier and ask which charge voltage they want you to use for their battery type, and select the closest to it. If totally confused then use the lower voltage setting until you have had a higher voltage setting confirmed to you by whoever supplied the batteries to you. **The de-sulphation cycle on switch position 8 is marked in red** because this is a very dangerous setting if you do not know what you are. doing. **Before even attempting to use this cycle you must clearly understand what it does and when and how you would use it.** What causes sulphation? This can occur with infrequent use of the batteries, or if the batteries have been left discharged so low that they will not accept a charge. **This cycle is very high voltage charge cycle designed to try to break down the sulphate 'crust' that is preventing the plates taking a charge and thus allow the plates to clean up and so accept charge once again.**

How to use this function. (only suitable for open lead acid batteries)

- 1) Ensure the battery bank is totally isolated from anything else on the boat or vehicle; the high voltage applied by this setting could destroy all your electronics and other electrical equipment still connected (hence all these instructions are in red, this is a very dangerous mistake.)
- 2) Make sure the battery compartment is very well ventilated and battery caps are removed.
- 3) Switch the battery type selector to the correct position, then switch the AC power on.
- 4) Because this is such a dangerous setting there is a 4 hr time out period build into the software, however on a very large battery bank this may not be enough and the unit may need to be switched off and on again to do another cycle.
- 5) What to expect on this cycle.

I would recommend you monitor the voltage of the sulphated battery bank. When you switch on the cycle the voltage should shoot up to the full 15.5volts very fast (within minutes) this is because the batteries cannot accept the charge (assuming they are sulphated). However, over a period of 1~2 hrs the voltage should start to drop (as the plates start to clean and the batteries start to take charge) the voltage could drop way down to about 12.5 volts then start to rise. These shows the batteries are now taking a charge and starting to fill up. In this case it would be safe to switch the unit off and select your normal charging curve and hopefully this will bring your batteries back from the dead. You may need to repeat the process a few times. Please note this is a professional guess tool, which most times helps, but its not magic, so expect the worst and hope for the best. **Never leave a system unattended when on this mode. If the battery temperature reaches above 50deg c (ie. If the batteries are almost too hot to touch) then stop the process).**

Install remote control.

Isolate the unit before attempting this so there are no high voltages. The local control panel on the front of the unit can also be used as a remote control, reveal the screws holding the panel onto the main box, carefully remove the panel and disconnect it from the connection socket behind the unit. Using the remote cable supplied then reconnect the panel to the unit

Operation and what to expect

- 1) After the unit is installed, using the panel on the front of the unit, and with the shore power (120/230VAC) still disconnected, switch the unit on. The leds will cycle through the test routine, then the unit should go into inverter mode and 120/230V should be produced on the output AC terminals(provided the batteries are over 11 volts).
- 2) If the above is ok, then connect the shore power to feed 120/130V into the PS LW, after a short while, the inverter should go off line, and feed the shore power through the inverter. Changeover is about 20 millisecs (so fast that you should not be able to notice it) and the battery charger should come online and go through it's charge sequence ending, after 110hrs, with float voltage.

Common Faults:

There are numerous faults which the unit can detect and transmit the fault to you by the use of LCD display and alarm on the unit itself. The remote control gives a little help but the real fault finding can only take place at the unit. Please see the fault finding chart over the page for full information.

Operation

It is easy to operate the inverter, please according to below instructions.

● Description of Panel

1. Description of Panel

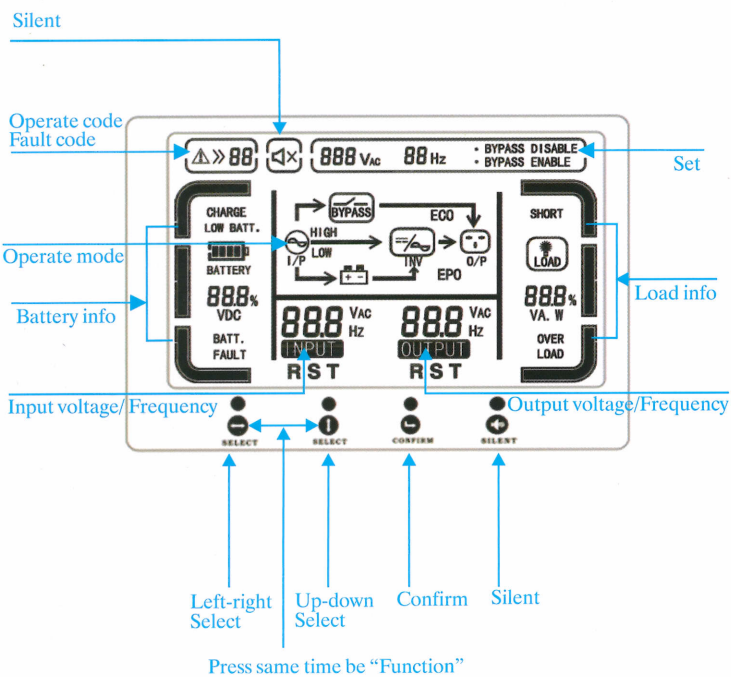

Keypress name	Function
Silent	Press it and hold over 3s, the inverter will be in silent mode, and press again over 3s, it will have sound again
Function	Press the two select buttons same time to enter into "function" mode, press over 2s, can set inverter specification
Left-right select	Only valid in "Function" mode, press over 1s, can change voltage and frequency choice
Up-down select	Only valid in "Function" mode, press over 1s, can change voltage and frequency choice
Confirm	Only valid in "Function" mode, press over 1s, can confirm new data.

2. Display meaning

Sign	Meaning
	When inverter is faulty, this sign will appear, behind it is fault code. Fan Over temperature 01; Overload 02, same time OVERLOAD sign will flash every 1s; Output short circuit 03; Over temperature 04; Low Battery voltage 05; Input output reverse 06; semi-wave short circuit (unusual load) 07; Over charge 08; Battery Over voltage 09.
	Mode display: 00 standby mode; 01 AC mode; 02 Invert mode; 03 Power saver mode.
	Silent mode in inverter mode, "X" means no sound.
	Display output voltage, can set 220V, 230V, 240V.
	Display output frequency, can set 50Hz, 60Hz. Autosense IF.
	Display battery left capacity and battery voltage, will change to the other info in every 3s.
	Display AC input voltage and frequency, will change to the other info in every 3s.
	Display AC output voltage and frequency, will change to the other info in every 3s.
	Bypass mode
	If show "HIGH" means AC input voltage high if show "LOW" means AC input voltage low. If AC is normal, will no show. If reverse L and N it will flash every 1s.
	Inverter mode
	Short circuit.
	Display load capacity: when VA value > W value, show VA value; when W value > VA value, show W value.
	Overload, flash every 1s.
	Load.
	Battery is charging.
	Low battery voltage, flash every 1s.
	Battery capacity

3. Fault Mode:

The upper left corner of the LCD shows the fault code and buzzer ringing.

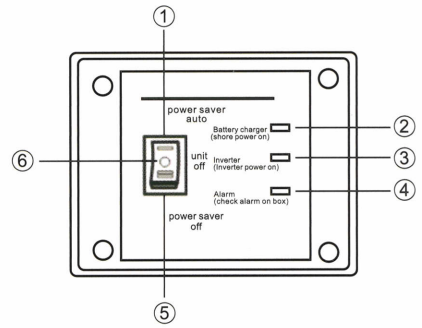
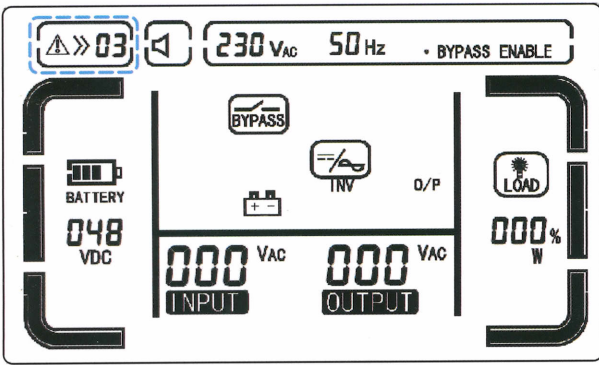

- ① Power save button
- ② Battery charge indicator
- ③ Invert indicator
- ④ Alarm indicator
- ⑤ Invert mode button
- ⑥ Close inverter button

● Operate mode

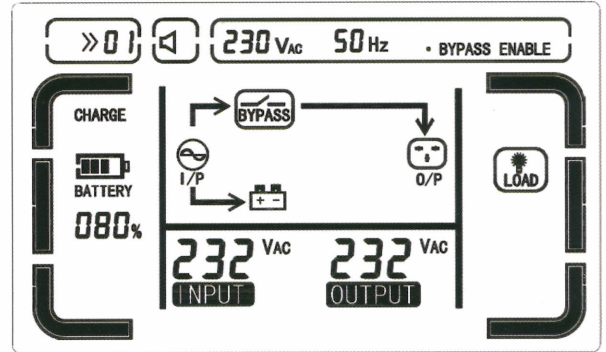

AC mode 01

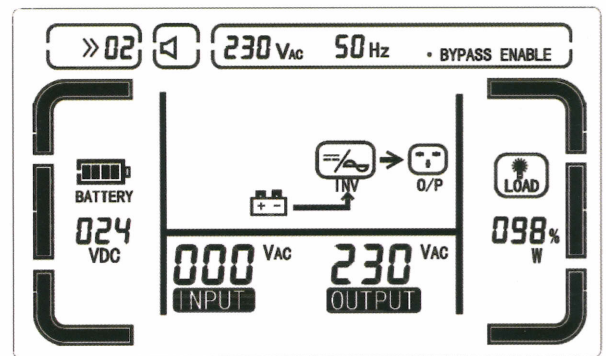

Battery inverter mode 02

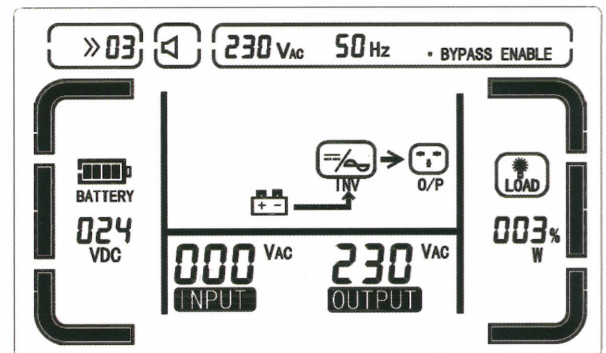

Power save mode 03
(at same time, "OUTPUT" and "O/P" signs flash)

Fault code meaning

Fault code	Fault	Reason and Solution
01	Over temperature, fan fault (alarm light on)	Inverter operate temperature is very bad, insufficient ventilation and indoor temperature is very high. Close inverter and wait for 10minutes, after inverter cool, start again. If fan fault, please replace with new fan.
02	Overload (alarm light on)	Connecting load power is over than inverter rated power, if reduce load equipments quantity, inverter will back to work.
03	Output short circuit (alarm light on)	Close inverter, and disconnect all load equipments, inspect load equipments if any of them has fault or internal short circuit, then start inverter again. If still fault, please consult with manufacturer.
04	Over temperature (alarm light on)	Inverter operate temperature is very bad, insufficient ventilation and indoor temperature is very high. Close inverter and wait for 10minutes, after inverter cool, start again.
05	Low battery voltage (alarm light on)	Battery damage; Battery deep discharge, so need to charge again; Inverter charger problem, please consult with manufacturer to replace.
06	Reverse input and output	Connect input and output again in correct way.
07	Semi-wave short circuit (unusual load)	Connecting load power is over than inverter rated power, if reduce load equipments quantity, inverter will back to work.
08	Over charge	Charger damage, please consult with manufacturer for replace.
09	Battery over voltage	Check if battery bank dc voltage is corresponding to this inverter request dc voltage.

● Operate

1. Battery mode

- 1) Power save mode: Press the "power saver auto" button; inverter will work in power save mode. (Only if connect with load, inverter will have output; if not connect with load, inverter will not have output).
- 2) Invert mode: Press the "Power saver off" button, inverter has output and work in invert mode.
- 3) AC mode: Connect with AC, AC indicators will light. Inverter will charge batteries and give ac output.

2. Close inverter: Press "Unit OFF" button, inverter will close and no output.

Note: If connect with generator, please according to below procedures:

1. Start generator, after it has run in normal, please connect its output with inverter input (must confirm no load connect with inverter when connecting), then start inverter. After inverter start, connect with load.
2. The watt of generator is better to be twice of inverter watt.

Parameter setting

1. Output voltage Setting

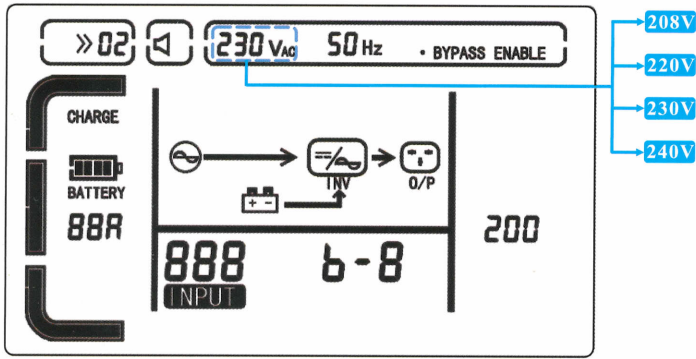

208Vac/220Vac/230Vac/240Vac four kinds of output voltage can be set.

2. Output frequency Setting

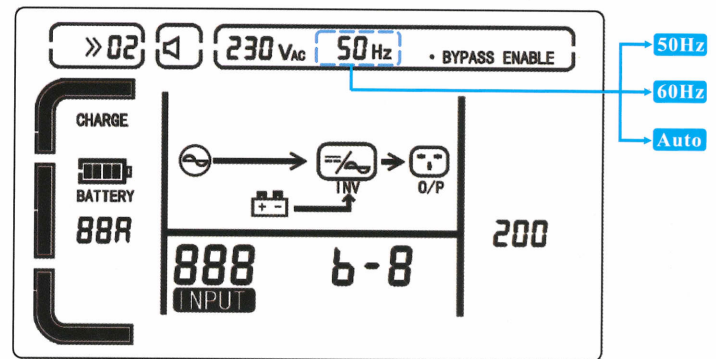

50/60Hz output frequency can be adjusted, as well as the adaptive AC input frequency.

3. Charger current Setting

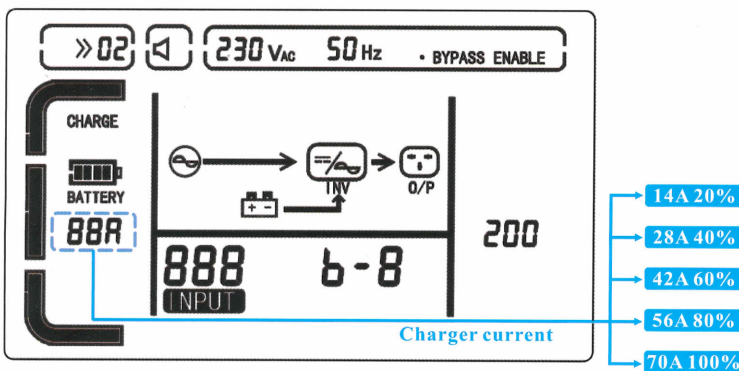

Maximum rated charge current can be divided into 5 different stages for adjustment.

20A charger can be adjusted into 4A/8A/12A/16A/20A.

35A charger can be adjusted into 7A/14A/21A/28A/35A.

50A charger can be adjusted into 10A/20A/30A/40A/50A.

70A charger can be adjusted into 14A/28A/42A/56A/70A.

90A charger can be adjusted into 18A/36A/54A/72A/90A.

4. DC/AC mode priority selection

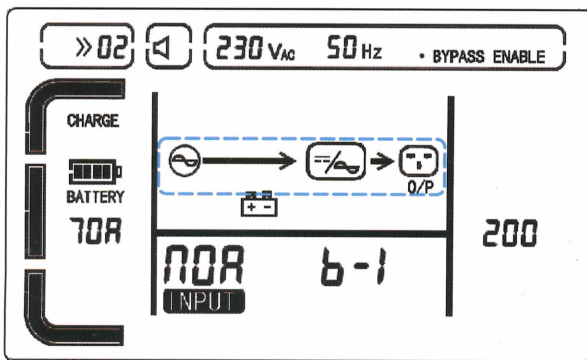

AC mode priority

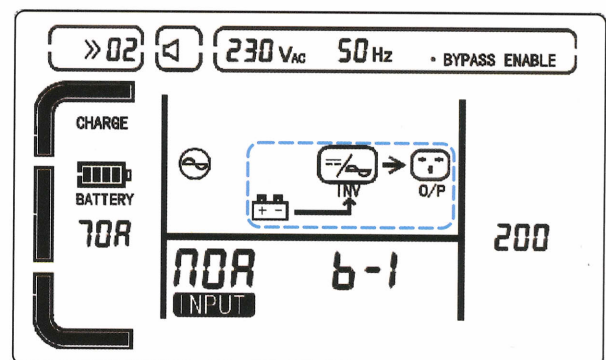

DC mode priority

5. Input voltage range

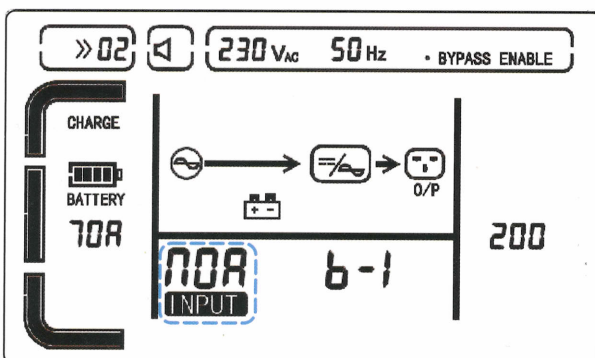

Narrow range mode

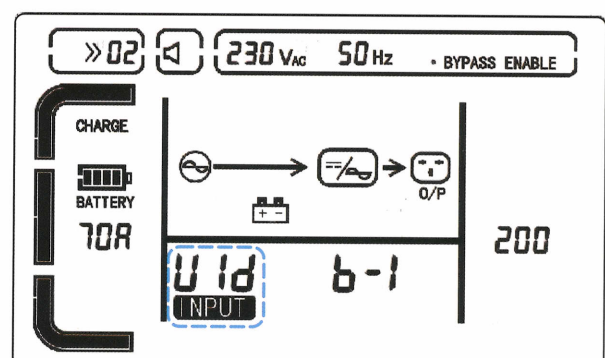

Wide range mode

6. Battery

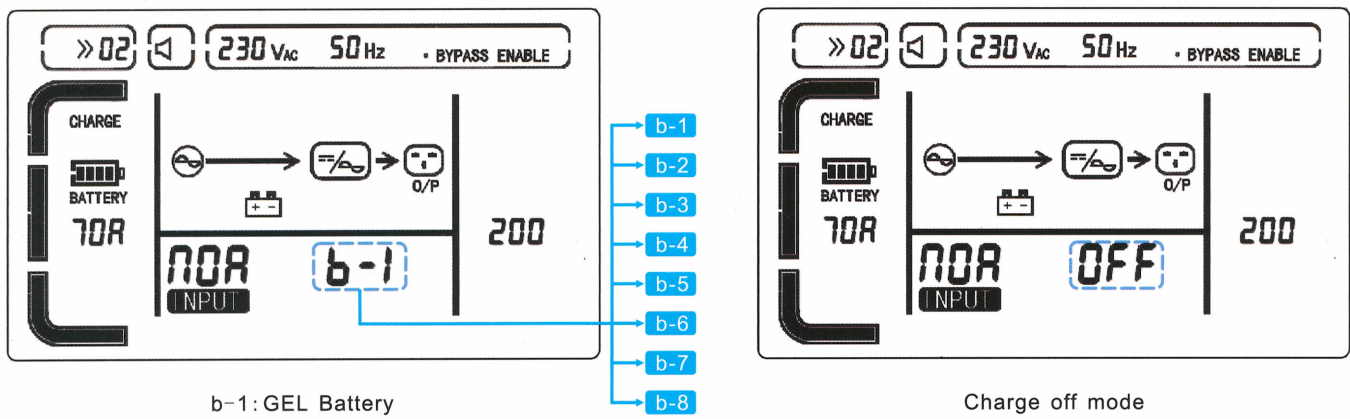

Battery type configuration parameter

LCD display	Battery Type	Fast V	Float V
b-1	AGM/GEL	14.0	13.7(*2 for 24V; *4 for 48V)
b-2	LiFePO4 16S/8S/4S	57.6/28.8/14.4	56.8/28.4/14.2
b-3	LiFePO4 16S/8S/4S	56.3/28.2/14.1	55.5/27.8/13.9
b-4	LiFePO4 16S/8S/4S	55.2/27.6/13.8	54.4/27.2/13.6
b-5	LiFePO4 15S	54.0	53.3
b-6	LiFePO4 15S	52.8	52.1
b-7	LiFePO4 15S	51.8	51.0
b-8	De sulphation cycle	15.5	for 4 hrs (*2 for 24V; *4 for 48V)
OFF	Turn off the charger		

7. Battery capacity

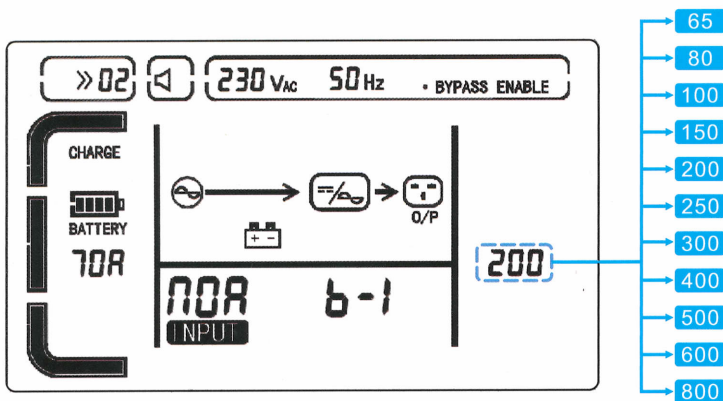

8. Battery low voltage shutdown point

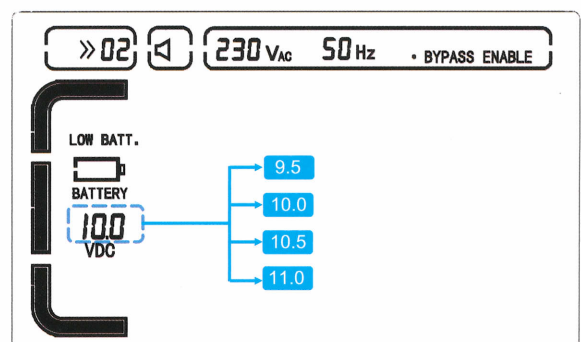

Battery capacity setting, select the battery capacity properly can make sure to display the right battery charging time and ensure that the battery is fully charged. If the battery capacity is not in the parameter, the close capacity is optional.

Capacity that is available in the LCD display as following :

65AH/80AH/100AH/150AH/200AH/250AH/300AH/400AH/500AH/600AH/800AH.

The factory default setting is 200AH.

Battery low voltage shutdown point

Battery low voltage shutdown point 9.5V/10.0V(default)/10.5V/11.0V.

General specification

Power star LW/LWS

Ordering Information

Input Wave Form:	Sine wave (Utility or Generator)								
Nominal Voltage:	120VAC				230VAC				
Low Voltage Trip:	85V±4%				184V/154V±4%				
Low Voltage re engage:	95V±4%				194V/164V±4%				
High Voltage Trip:	140V±4%				263V±4%				
High Voltage re engage:	135V±4%				253V±4%				
Max Input AC Voltage:	150VAC				270VAC				
Nominal Input Frequency:	50Hz or 60Hz (Auto detect)								
Low freq trip:	40Hz for 50Hz				50Hz for 60Hz				
High freq trip:	55Hz for 50Hz, 65Hz for 60Hz								
Output wave form:	(Bypass mode) same as input								
Overload protection:	Circuit breaker								
Short circuit protection:	Circuit breaker								
Transfer switch rating:	30amp or 40amp								
Efficiency on line transfer mode:	95%								
Line transfer time:	10ms Typical								
Bypass without battery connected:	Yes								
Max bypass current:	30amp or 40amp								
Bypass over load current:	35amp or 45amp: Alarm								
Inverter Specification/output									
Output wave form:	Pure sine wave								
Output continuous power Watts:	1000	2000	3000	4000	5000	6000	7000	8000	
	1000	2000	3000	4000	5000	6000	7000	8000	
Power factor:	0.9-1.0								
Nominal output voltage rms:	120/230VAC								
Output voltage regulation:	± 10% RMS								
Output frequency:	50Hz ± 0.3Hz or 60Hz ± 0.3Hz								
Nominal efficiency:	>85%								
Surge ratings:	3000	6000	9000	12000	15000	18000	21000	24000	
Short circuit protection:	Yes, fault after 10 secs								
Inverter Specification/input									
Nominal Input voltage:	12V	24V	48V	72V					
Minimum start voltage:	10V	20V	40V	60V					
Low battery alarm:	10.5V	21V	42V	63V					
Low battery trip:	10V	20V	40V	60V					
High voltage alarm:	16V	32V	64V	96V					
Power saver:	Below 25 watts when enabled								
Power saver:	Same switched on/off on remote								
Charger Mode specification									
Input voltage range:	85-140VAC or 184-263VAC								
Output voltage:	Dependent on battery type								
Charger current:	15A/20A/35A/50A/70A/90A								
Battery initial voltage for start up:	10-15.7v for 12v(*2 for 24v,*4 for 48v,*6 for 72v)								
Over charge protection shutdown:	15.7v for 12v(*2 for 24v,*4 for 48v,*6 for 72v)								
Charger curve(4 stage constant current)Battery types									
4 step digital controlled progressive charge									
Battery type:	Fast V	Float V (*2 for 24v,*4 for 48v,*6 for 72v)							
b-1:AGM/GEL	14.0	13.7 (*2 for 24V,*4 for 48V)							
b-2:LiFePO4 16S/8S/4S	57.6/28.8/14.4	56.8/28.4/14.2							
b-3:LiFePO4 16S/8S/4S	56.3/28.2/14.1	55.5/27.8/13.9							
b-4:LiFePO4 16S/8S/4S	55.2/27.6/13.8	54.4/27.2/13.6							
b-5:LiFePO4 15S	54.0	53.3							
b-6:LiFePO4 15S	52.8	52.1							
b-7:LiFePO4 15S	51.8	51.0							
b-8:De sulphation cycle	15.5	for 4 hrs (*2 for 24V,*4 for 48V)							
Remote control/RS232/USB									
Size: in mm	Yes. Optional								
	1000-3000W Model:460*220*190mm								
	4000-6000W Model:650*220*190mm								
	7000-8000W Model:650*240*190mm								
Weight:	1000W	1500W	2000W	3000W	4000W	5000W	6000W	7000W	8000W
	16kg	18kg	20kg	25.5kg	36kg	39.5kg	48kg	53.5kg	59kg

Typical part number ▶ LW - 1000 - E - 12 - C

- 1. Basis series**
Low frequency pure sine wave Inverter & Charger
- 2. Power Rating**
1000=1000W 2000=2000W 3000=3000W
4000=4000W 5000=5000W 6000=6000W
7000=7000W 8000=8000W
- 3. AC Voltage**
E=120VAC NC=230VAC
- 4. Battery Voltage**
12=12VDC 24=24VDC 48=48VDC 72=72VDC
- 5. Display**
C=LCD Display NC=LED Display

Typical part number ▶ LWS - 1000 - E - 12 - C

- 1. Basis series**
Low frequency pure sine wave Inverter & Charger
- 2. Power Rating**
1000=1000W 2000=2000W 3000=3000W
4000=4000W 5000=5000W 6000=6000W
7000=7000W 8000=8000W
- 3. AC Voltage**
E=120VAC NC=230VAC
- 4. Battery Voltage**
12=12VDC 24=24VDC 48=48VDC 72=72VDC
- 5. Display**
C=LCD Display NC=LED Display

Product specifications are subject to change without further notice.

Remote control installation

Remove 4 screws holding this panel and disconnect the cable behind it



Remark:

LW only can be turned on after connected to batteries.

LWS can be turned on without connecting batteries, after connected AC, with bypass output and can charge the batteries.