

Read the full manual before using this product

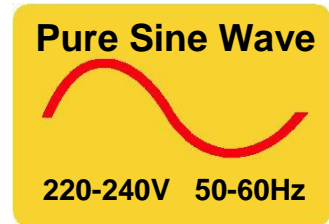

Low Frequency Inverter

User Manual



*For LK/LW series Power Star inverters only, models:
LK2000, LK2000-24, LK3000, LK3000-24, LK3000-48, LK6000-24, LK6000-48*

1. Safety precautions

WARNING! HIGH VOLTAGE! Do not install this product unless qualified to do so. Read the full user manual before working on this product.

- *Electricity can be very dangerous! Never touch bare wires, connectors or terminals.*
- *Do not open the inverter case, nor should you try to repair it if broken.*
- *Avoid any contact with water. Never operate the inverter in an environment where, or in conditions when, contact with water is likely or humidity is high.*
- *Avoid any contact with oil or grease.*
- *Keep the inverter, cables and other components of your system away from children.*
- *Never connect the inverter output to any other AC power source.*
- *Do not cover the inverter. Always place it in a well-ventilated environment and allow space around the inverter for airflow.*
- *If you operate the inverter in a vehicle, boat or any other mobile application, secure the inverter to prevent it from any movement while the vehicle is in motion. Make sure all the connections are tight.*
- *Do not place the inverter under direct sunlight or in a high temperature environment.*
- *Keep the inverter away from any flammable substances.*
- *Do not use the inverter in an enclosure containing any type of lead-acid batteries which might vent explosive gases.*
- *Always switch on the inverter first, before plugging in any appliances.*

The product should be handled and installed by professionals or appropriately qualified persons. Suitable precautions and safety measures should be taken in all cases.

1. Product overview

Dear Customer,

Thank you for buying this low-frequency inverter. It has important advantages over high frequency inverters, such as peak power handling capacity and reliability. This low-frequency inverter can operate at the peak power level substantially higher than the nominal power, for a period of several seconds – which is great for starting appliances with high initial power draw (e.g. electric motors). The inverter also operates using a powerful transformer (as opposed to electronic switching components in high frequency inverters) - this results in a stronger, sturdier inverter which is less prone to damage.

In addition to the standard function of inverting the power (i.e. converting the battery DC electricity into mains AC 230V 50Hz electricity), this inverter has other useful features and components:

- It has a mains AC input which can take power from the national grid or a generator. The inverter is also equipped with a powerful built-in mains charger for charging the batteries (suitable for lead-acid battery types only), with programmable operating charging current;
- When the mains AC input power is connected the inverter will activate the power transfer switch to work in a “bypass” mode, where the AC input mains power will be directly connected to the AC output, therefore “bypassing” the *battery-to-output* inverter circuit. The active mains input will also switch on the in-built battery charger unless the charger is set to OFF.
- The inverter can work as an uninterruptible power supply (UPS) unit. By default, when the mains AC power input is connected and active, it will be connected to the mains AC output through the bypass transfer switch, powering the appliances directly. If suddenly there is a power cut or mains AC input is not available for any other reason, the inverter will automatically connect the batteries and start running the mains AC output from the batteries – without any interruption to the appliances.
- There is also a choice of operating modes: *AC priority* or *battery (or DC) priority*:
 - o In the *AC priority* mode, while the inverter is connected to the mains AC input, it charges your batteries from mains all the time. Your appliances are also powered by mains.
 - o In the *battery (or DC) priority* mode, even if the mains AC input is connected to the inverter, it remains deactivated and your appliances are powered by the batteries until the batteries get too low.

You will find more details about these modes in the Settings section of this manual.

This inverter is powerful enough to run heavy duty appliances with large starting current or power spikes. When running smaller appliances, for energy saving purposes, the inverter On/Off switch has two On positions:

- “Power saver off”: this is the full power mode, in which the inverter supplies full power to the mains output.
- “Power saver auto”: this is the standby or energy saving mode. When the inverter doesn’t have any load drawing power from its output, it goes into a standby “sleep” mode and switches off the mains AC output. During this time the inverter uses a reduced amount of power from the battery. If an appliance is plugged into the inverter AC output, the inverter exits the standby “sleep” mode immediately and starts supplying the full power again to the mains AC output. The load has to be in

excess of 25W to wake up the inverter, i.e. plugging something small such as a mobile phone charger will not make a difference and the inverter will remain in the standby “sleep” mode.

2. Installation and wiring

Before you install the inverter, ensure that it has the correct DC voltage for your system, i.e. the inverter DC input voltage matches the voltage of your battery bank. For example, if your inverter is 12V (or 24V / 48V), only use it with a 12V battery bank (24V / 48V bank respectively). **Incorrect battery voltage might damage the inverter.**

Position the inverter in a cool, dry, well ventilated space as close to the main battery bank as possible, to make sure that the DC battery cables are as short as possible. Remember that long cables might cause a voltage drop in the inverter incoming power supply which will affect the systems performance. The unit can be mounted in any position – on a horizontal or vertical surface.

The overall wiring diagram for the inverter is provided below.

*Wiring diagram for
LK/LW Series Power Star inverters*



Ensure that the inverter is switched off during the installation. It is recommended that you always connect the inverter to the battery bank first, as the battery power ultimately starts the inverter. If the inverter is connected to the AC input only, with the batteries disconnected or too low, the inverter will not switch on.

It is very important to choose the right cables depending on the length which you require between the inverter and the battery bank. This is both for efficiency and safety reasons. The following table provides guidance on the recommended cable cross section (area in mm² of the metal core of the cable):

Product code	Cable length 0-1.5m	Cable length 1.5-4.0m
LK2000-24 (2000W 24V), LK3000-48 (3000W 48V),	25mm ²	35mm ²
LK3000-24 (3000W 24V), LK6000-48 (6000W 48V)	35mm ²	50mm ²
LK2000 (2000W 12V)	50mm ²	70mm ²
LK3000 (3000W 12V), LK6000-24 (6000W 24V)	70mm ²	90mm ²

Read the full manual before using this product

The above table relates to the multi strand copper cable (for marine applications tinned copper is recommended). If the cable you intend using is different (such as single strand or aluminium) or you require distances longer than 4m, please contact your inverter supplier or distributor for advice.

Please note that if there is a problem obtaining, for example, a 90mm² cable, you can purchase 2 x 50mm² cables or even 3 x 35 mm² cables. To use one cable is always preferred but it does not matter whether one cable or multiple is used, as long as the square areas add up to the same or higher than the required. The performance of any system can be increased by having thicker and shorter cables, so it is advised to keep the length as short as possible. If you can't source the cable for the inverter locally, your inverter supplier or distributor should normally be able to offer you this cable.

When connecting the inverter to the battery using the correct heavy duty cable, follow the guidelines below:

- Connect the cable through a suitable fuse with an isolator switch, or a circuit breaker. The minimum current rating of such fuse / switch / circuit breaker depends on the input voltage of your inverter and the nominal rated power. For example, if your inverter is 3000W 24V, then at nominal power 3000W it would draw around $3000W / 24V = 125A$ from the battery. So the fuse / switch or a circuit breaker should be rated at 125A. This assumes that the inverter is not intended for loads which will have a peak power in excess of 3000W (in such case the amp rating of the fuse / switch or a circuit breaker should be higher).
- The fuse (or a circuit breaker) should be fitted as close to the battery terminal as possible, ideally within 15cm from it. This way it will protect the full length of cable from the battery to the inverter from a potential short circuit. In most cases it is installed on the positive cable.
- After fitting the fuse / switch / circuit breaker, it is advised to connect the cable ends to the inverter terminals first. Keep the switch or a circuit breaker in Off position. Only after that should you connect the other end of the cable to the terminals of your battery bank: red positive (+) terminal of the inverter to the positive (+) of your battery bank, and black negative (-) of the inverter to the negative (-) of your battery bank.
- Cables joining batteries in your bank should be similar or thicker than the inverter cables.

WARNING! Do not reverse the polarity of the battery cables. If the battery bank is connected to the inverter with the wrong polarity, the inverter will be damaged.

The next step is wiring the AC output and AC input of the inverter. Keep the inverter switched off during this procedure. The overall connection scheme is provided below.

Wiring AC input and output terminals of LK/LW Series Power Star inverters

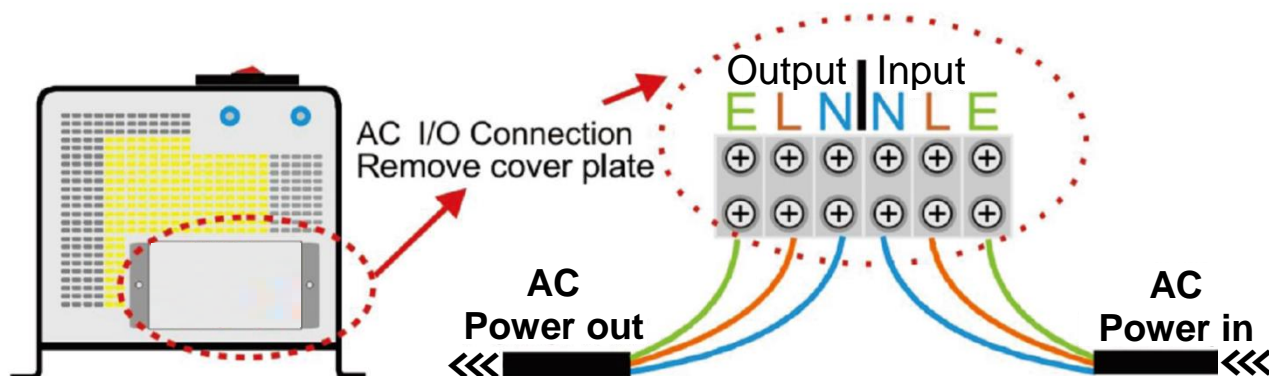

Read the full manual before using this product

Remove the cover on the AC side of the inverter to access the AC terminals. The inverter has 3 terminals for the AC output (Live, Neutral and Earth) and 3 terminals for the mains AC input (Live, Neutral and Earth). If your inverter includes an AC output socket, internally this socket is connected to the AC output terminals.



Note: the order of output and input AC terminals of your inverter might be different compared to the order shown on the diagram above. Always follow the signs printed on the inverter casing to identify the correct terminals.

When wiring the AC output of the inverter from the socket or AC output terminals:

- Make sure that all other AC power sources are fully isolated from the circuits to which you intend to connect the inverter AC output. *If you connect the inverter AC output to a circuit which already has live AC power in it, the inverter will be damaged immediately.*
- Use a suitable Residual Current Device (RCD) on the inverter AC output for safety and protection.
- The inverter has a built-in AC output circuit breaker rated at 30A. If you intend to use the inverter with smaller AC loads, it is recommended that you install a smaller fuse (3A, 10A, 13A) on the AC output of the inverter (or use appropriately fused plugs / sockets).

We recommend multi core tri rated AC cable when the inverter is used on a boat or on a vehicle as this is much safer when vibration is likely. A single solid household AC cable is suitable if the product is being used as a power source for a house or installation free from vibration.

The inverter also has a 30A circuit breaker installed on the AC input side. If you are planning to use the inverter with reduced through-power (including “bypass” and battery charging), install a smaller fuse on the AC input of the inverter, e.g. 3A, 10A or 13A.

When connecting the inverter earth, please note that the earth wires for AC input and AC output are connected inside and both are connected to the inverter case. Use a suitable earthing cable to connect the inverter casing to the boat's earth or a bonding system, vehicle chassis or an earthing rod (for stationary installations).

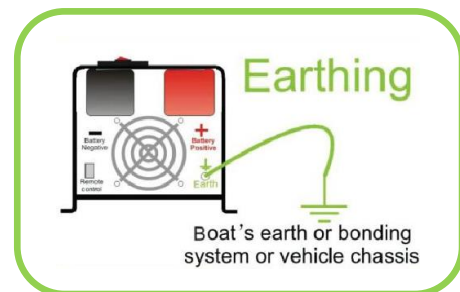

To complete this part of the installation and test the unit: after the inverter has been connected to the battery bank turn the isolator switch between the inverter and the battery on. Then turn the On/Off switch of the inverter to “Power Saver Off” position. The LEDs will cycle through the test routine and the unit should go into the inverter mode and 230V AC should be produced on the output AC terminals.

When the AC battery charging or mains input power is required connect the AC input to the inverter and it will enter the “bypass” mode to start supplying the input AC power to the output AC power directly. The changeover to mains AC input takes about 10 milliseconds and is hardly noticeable. If the battery charger is On (default setting) it will start charging the battery bank according to the pre-programmed battery charging stages (see Appendix 1 for more details).

Installing the remote On/Off control (can be purchased separately)

If you have purchased a remote On/Off switch with 5m cable for your inverter, it can be plugged into the “Remote control” socket located on the battery terminals side of the inverter.

Read the full manual before using this product

Keep the inverter **turned off** when you plug the remote switch for the first time. In the future, always make sure to keep the main switch of the inverter in **Off (middle) position** if you intend to use a remote switch connected via the “Remote control” socket.

If you haven't bought a separate remote On/Off switch, the built-in black On/Off control panel on top of the inverter can be used as a remote switch. For that disconnect the inverter from the battery and AC, then turn the inverter On for 5 sec. to discharge internal capacitors. Remove 4 screws holding the panel, take it out and disconnect the cable from the socket inside. Use a suitable length/grade 6-pin RJ11 extension cable to move the black On/Off panel to the new location. Cover the hole in the inverter case thoroughly with tape.

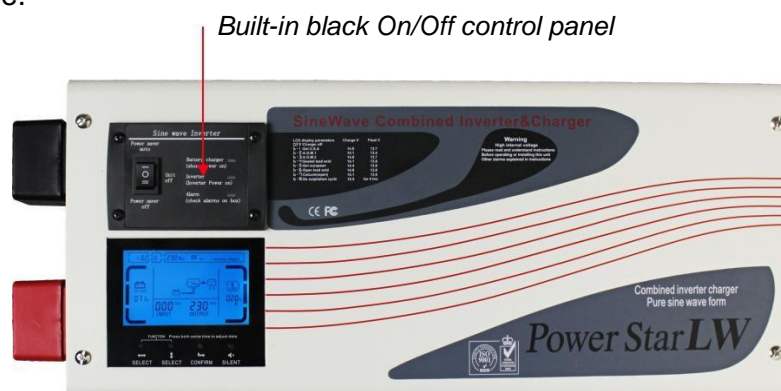

Connecting a generator

This inverter can accept power from a generator connected to the mains AC input of the inverter.



Note: for best performance, it is recommended that the generator nominal power rating is twice as high as the nominal power of the inverter. Lower power rating of the generator might cause a problem when the inverter works with high loads.

To proceed with the installation of the generator, keep the inverter off and start the generator. When it is ready and running at normal speed, connect the generator's output to the inverter's AC input terminals. There must be no load connected to the inverter (nothing connected to the AC output of the inverter) at this point. Then, turn on the inverter. At this point the load can be connected.

3. Operation modes

The inverter main switch panel has a 3-position rocker switch and 3 LED lights:

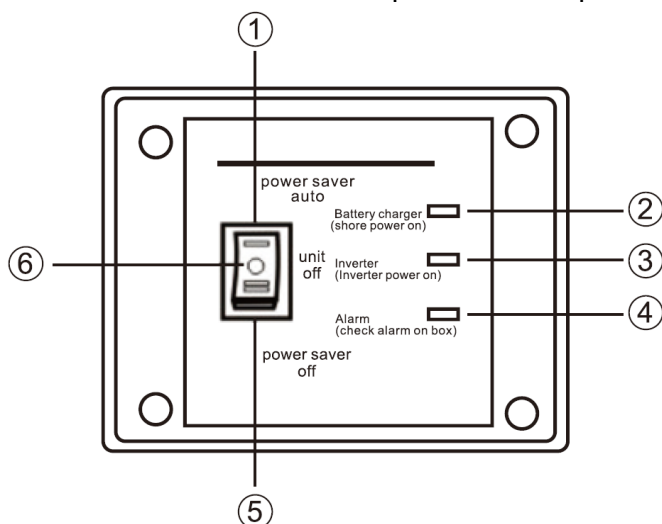

(1)	Switch: power saver auto position
(2)	Battery charge LED indicator
(3)	Inverter work LED indicator
(4)	Alarm and fault LED indicator
(5)	Switch: power saver off position
(6)	Switch: unit off (middle) position

According to the switch position, the inverter will have one of the following modes:

- **Unit off** (middle position): The inverter is off, there is no AC output. The battery charger is off.
- **Power saver off**: the inverter is producing full power. The exact operating mode depends on whether AC input power is connected to the inverter or not. If the AC input is connected, the inverter will be operating in the bypass mode and the battery charger will be working.
- **Power saver auto**: the inverter is in the sleep mode and will only provide power if a load is connected to the AC output. If there is no load connected, the inverter will continue 'sleeping' to save energy. Please note that the load must exceed 25W to turn on the inverter output – small loads such as mobile phone chargers, LED lights etc will not be enough to exit the sleep mode.



If you want to change the active “**Power saver auto**” mode to “**Power saver off**” and vice versa, turn the switch to the middle position “**Unit off**” first, wait until the inverter switches off, and then switch it into the other mode.

The detailed description of these operating modes is provided below.

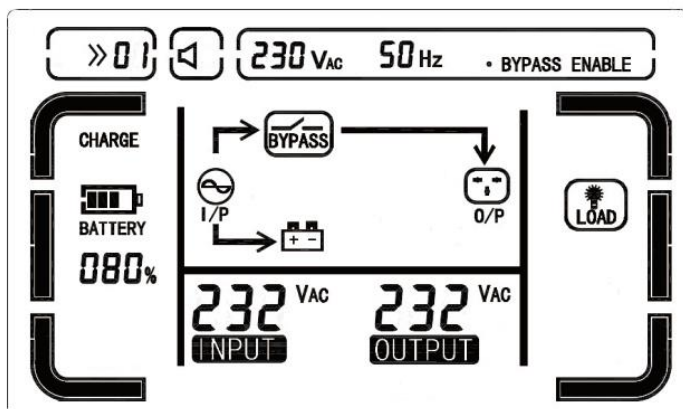

Power saver off, AC input is connected. If the AC input is connected, the inverter will be working in the **AC mode 01** (in the top left corner of the inverter LCD display there will be a sign “>> 01”) as shown on the picture. In the centre of the screen the input (I/P) sign will have arrows pointing from it to Bypass and battery icons. The display will show AC input voltage at the bottom, as well as AC output.

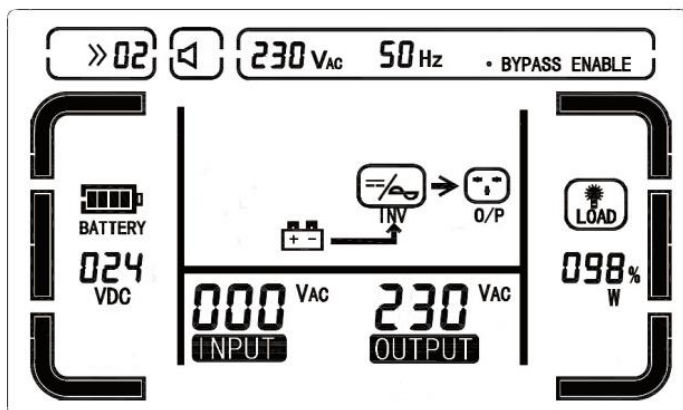

Power saver off, AC input is disconnected. If the AC input is disconnected, the inverter will be working in the **Battery (inverter) mode 02** (in the top left corner of the inverter LCD display there will be a sign “>> 02”) as shown on the picture. In the centre of the screen there will be an arrow pointing from the battery to the inverter and to output (O/P). AC input voltage will show 000V.

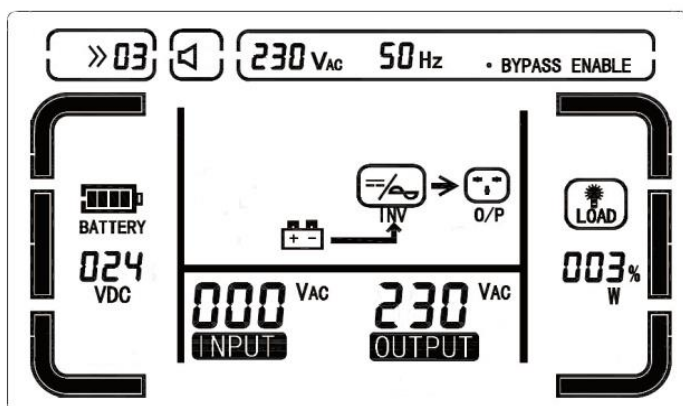

Power saver auto. The inverter will be working in the **Power saver mode 03** (in the top left corner of the inverter LCD display there will be a sign “>> 03”) as shown on the picture. The inverter will be 'sleeping' in standby until a load (>25W) is connected to the inverter output. The signs “OUTPUT” and “O/P” will be flashing on the screen.

4. LCD display

The inverter shows operational information and provides access to various settings via the LCD display.

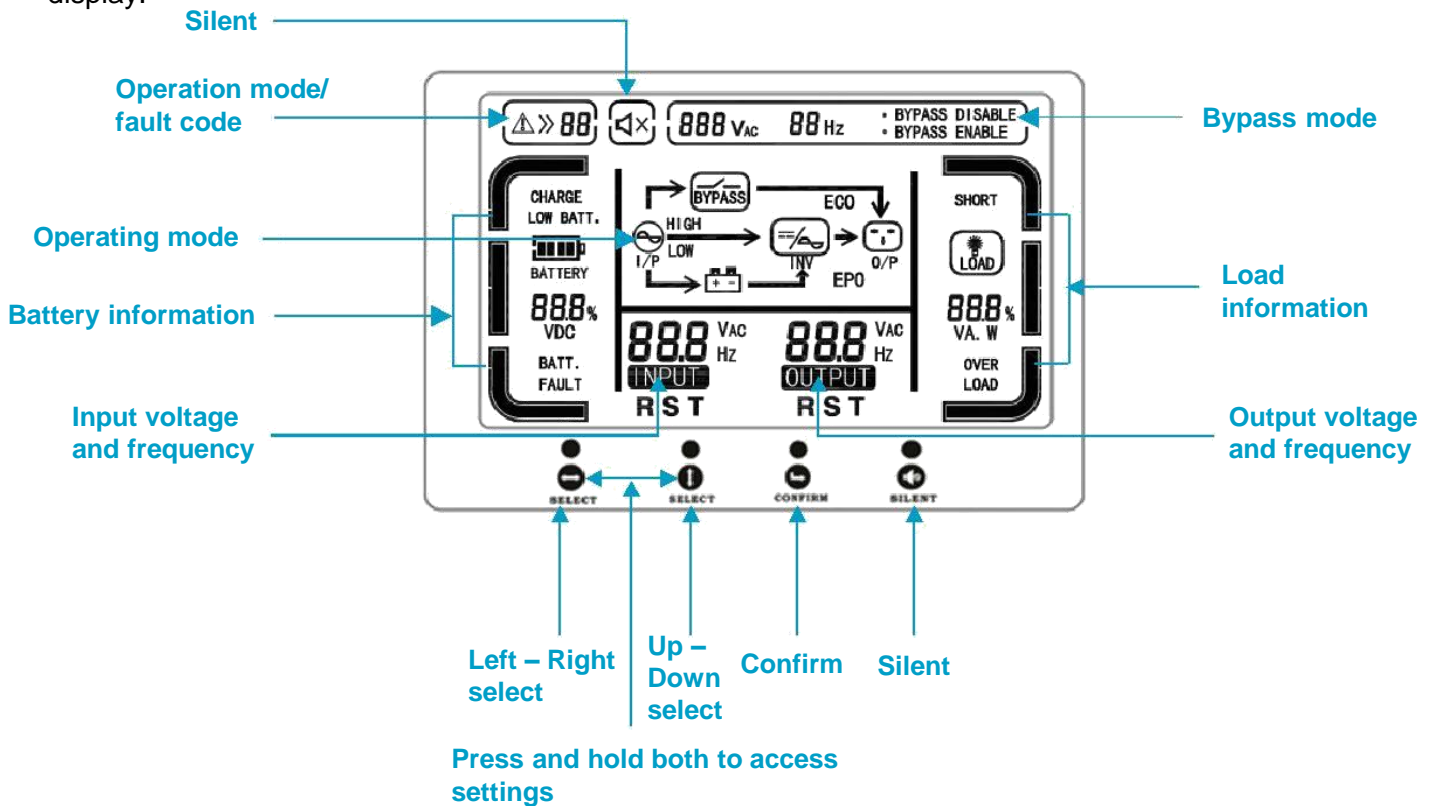

The table below provides information about various signs on the LCD display and their meaning.

Sign	Meaning
	When a problem happens, this sign appears with a fault code next to it (see Troubleshooting)
	Operating mode (see Operating Modes)
	Silent mode in inverter mode
	Displays the output voltage which can be set to 220V, 230V or 240V
	Displays the output frequency which can be set to 50Hz, or 60Hz.
	Displays and alternates every 3 sec. between the current battery capacity as a % and battery voltage.
	Displays and alternates every 3 sec. between AC input frequency and voltage.
	Displays and alternates every 3 sec. between AC output frequency and voltage.
	The inverter is working in the bypass mode

	If the display shows HIGH, the AC input voltage is too high. If it shows LOW, the AC input voltage is too low. If L (live) and N (neutral) is reversed it will flash every 1 second.
	The inverter is working in the inverting mode
	There has been a short circuit detected
	Displays the load capacity in either VA or W whichever is higher
	Too much power is being drawn through the inverter. Flashes once a second.
	The load is connected
	The battery is charging
	Low battery warning, flashes once a second
	Shows the battery capacity

Read the full manual before using this product

The main functions of the 4 buttons under the LCD display are described below.

Button	Function
Silent	Press and hold for 3 seconds to switch between silent and sound mode.
Settings	Press the two select buttons and hold them for 2 seconds to enter the <i>Settings mode</i>
Left-Right select	Only valid in the <i>Settings mode</i> . Used to select a different parameter. Hold it for > 1 sec.
Up-Down select	Only valid in the <i>Settings mode</i> . Used to select a value or type of a particular parameter. Hold it for > 1 sec.
Confirm	Only valid in the <i>Settings mode</i> . Used to confirm new data. Hold it for > 1 sec.

5. Settings

To access the settings menu of the inverter please follow the steps below:

1. Switch the inverter On in the **Power Saver Off** mode.
2. Wait for 3 seconds and then press ⇔ and ⇅ buttons together and hold them for a further 3 seconds. The inverter will 'Beep' and the first editable parameter will start flashing on the screen.
3. Press ⇔ to navigate through the different parameters to set.
4. Select a setting and it will begin to flash. Press ⇅ and follow the instructions below to choose different options.
5. Once you have finished the changes, press CONFIRM ↵ to record the new settings. The inverter will make a beeping sound to confirm. **Restart the inverter** by switching it OFF and then ON for the settings to take effect.

Setting 1: Output AC voltage (208 ⇅ 220 ⇅ 230 ⇅ 240)

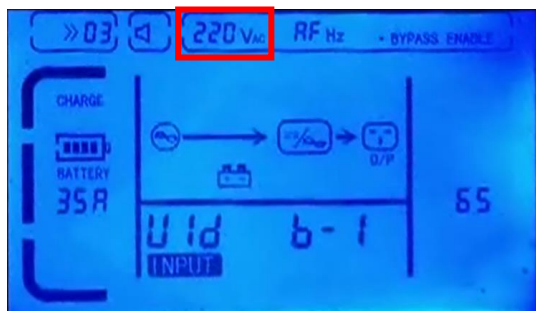

This setting is to provide the right AC output voltage for your electronic appliances. The default voltage range for appliances in the UK is 230V - 240V AC; other countries might have different requirements.

After selecting the required AC output voltage, press ⇔ to move to the next parameter.

Setting 2: Output AC frequency (AF ⇅ 50 ⇅ 60)

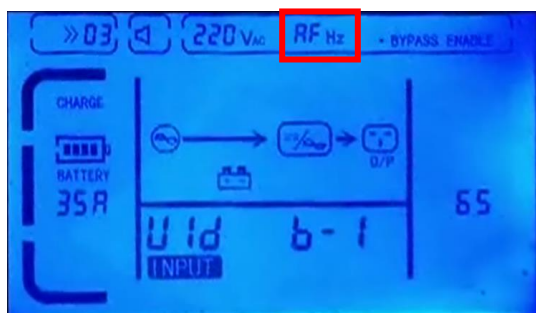

This setting is for the output frequency. Choose from AF (auto detection of frequency), 50Hz or 60Hz. The default value for the UK is 50Hz. If this parameter is set to AF, the inverter can detect the frequency from the mains AC input.

Setting 3: Charging current (different for each inverter model)

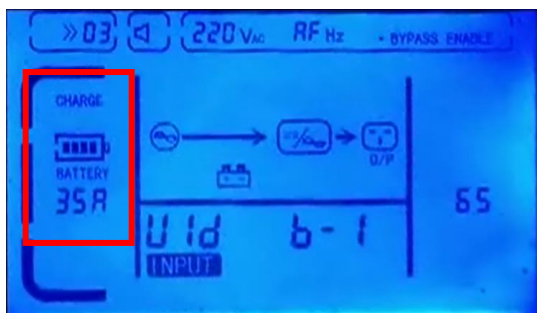

You can choose the *operating charging current* (A) for charging your batteries from the mains AC input of the inverter. **Please note that some batteries have restrictions on the maximum charging current they can accept**, and too high current / too quick charging might be damaging for them. Check with the user manual / datasheet / the supplier or manufacturer of your batteries about the optimal charging current for them.

Depending on the inverter model, you can set the following *operating charging current*.

Inverter model	Charging current
LK2000 (2000W 12V)	14A / 28A / 42A / 56A / 70A
LK2000-24 (2000W 24V)	7A / 14A / 21A / 28A / 35A
LK3000 (3000W 12V)	18A / 36A / 54A / 72A / 90A

LK3000-24 (3000W 24V)	14A / 28A / 42A / 56A / 70A
LK3000-48 (3000W 48V)	7A / 14A / 21A / 28A / 35A
LK6000-24 (6000W 24V)	14A / 28A / 42A / 56A / 70A
LK6000-48 (6000W 48V)	7A / 14A / 21A / 28A / 35A

Setting 4: Priority working mode (AC priority ⇄ DC priority)

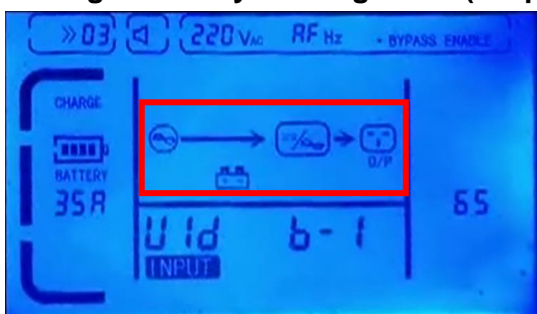

There are two different working modes of your inverter to choose from – **AC priority** and **DC priority**.

In the **AC priority mode**, while the inverter is connected to the mains AC input, it charges your batteries from mains all the time. The mains input is also linked to the mains output, so your loads are not powered by the battery, but only by the mains input. In this mode the inverter works like UPS (uninterrupted power supply) – if the mains power suddenly switches off, the inverter will continue running your appliances from the battery without any interruption.

In the **DC priority mode**, even if the mains input is connected to the inverter, your appliances are still powered by the batteries. The batteries are not being charged from the mains until they are running low. So only when the batteries become discharged, the AC mains input gets activated automatically to start charging them and providing power to your loads. This working mode is designed to use as much power as possible from the batteries (before starting to use mains power) and it is ideal when you use **solar power** to charge your batteries.

The **AC priority mode** is shown on the screen when the arrow is pointing from the generator symbol to the output (O/P) as on the above picture in the red area. The **DC priority mode** is shown when the arrow on the screen is pointing from the battery symbol.

Setting 5: Input AC Voltage (NOR – normal ⇄ Uld – wide)

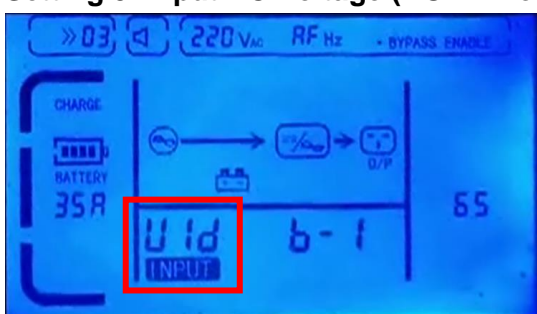

The inverter has a min and max limit for the AC input voltage. When one of these limits is reached, the inverter shuts down automatically for protection. This function is designed to make sure the input voltage stays within the acceptable range and the risk of damage to your appliances is minimal.

Read the full manual before using this product

NOR (normal mode) will have the normal input voltage limits and it should be used in areas with stable power supply. **UId** (wide mode) pushes the limits further and makes the acceptable input voltage range wider. This mode can be used in places with high fluctuation in the mains voltage.



Please note that, if you have power spikes in your area, you should use an adequate mains surge protection filter between the inverter and the mains AC input to minimise the risk of damage to your inverter.

The table below gives information on the mains voltage thresholds for different inverter actions.

	Output Voltage	Utility disconnect	Utility re-connect	Charge disconnect	Charge re-connect
Normal (NOR)	208V	174-263Vac	184-253Vac	184-253Vac	190-248Vac
	220/230V	184-263Vac	194-253Vac	194-253Vac	200-248Vac
	240V	184-273Vac	194-263Vac	194-263Vac	200-258Vac
Wide (UId)	208V	125-263Vac	135-253Vac	155-253Vac	160-248Vac
	220/230V	135-263Vac	145-253Vac	160-253Vac	165-248Vac
	240V	135-273Vac	145-263Vac	160-263Vac	165-258Vac

Setting 6: Battery type (b-1 ⇅ b-2 ⇅ b-3 ⇅ b-4 ⇅ b-5 ⇅ b-6 ⇅ b-7 ⇅ b-8 ⇅ 0)

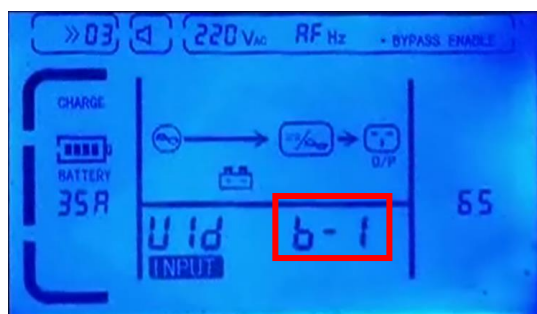

The inverter has several charging programmes for different battery types with different charging voltages. Choose the correct battery type for accurate battery charging. If needed, consult your battery manual or battery manufacturer / supplier for the right level of charging voltage for your battery. The table below provides information about different battery types and voltage levels.

Setting	Charge Voltage*	Float Voltage*
b – 1 (Gel USA)	14.0	13.7
b – 2 (AGM)	14.1	13.4
b – 3 (AGM)	14.6	13.7
b – 4 (Sealed lead acid)	14.1	13.6
b – 5 (Gel EUROPE)	14.4	13.8
b – 6 (Open lead acid)	14.8	13.8
b – 7 (Calcium open)	15.1	13.6
b – 8 (Desulphation cycle)	15.5 for 4 hours	
0 (Charger not required)	Battery charger is off	

* The voltages are provided for 12V batteries. For 24V multiply by x2, for 48V multiply by x4.

The desulphation cycle is marked in red because this is a very dangerous setting. Please see [Appendix 2](#) for more information.

Read the full manual before using this product

There is a wide variety of battery types from a variety of suppliers, with various specifications and requirements. In order to choose the best type for your battery bank, choose the setting which delivers the closest charging voltage to the level required by your batteries. You can normally find the charging voltage requirements for your batteries in the user manual or by contacting your battery supplier or manufacturer. Alternatively, you can select the type of battery which delivers the lowest charging voltage.

Setting 7: Battery capacity (in Ah)

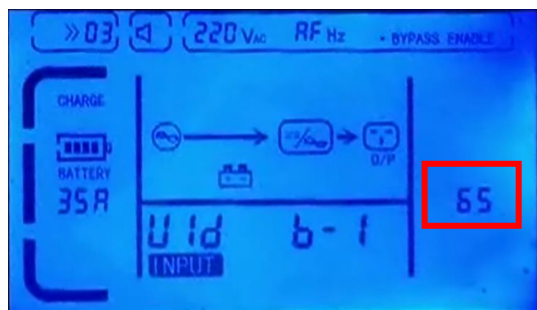

You can set the capacity of your battery bank (in Ah) on the inverter to further optimise the charging process. Choose the closest capacity value to your battery bank (e.g. for 480Ah battery bank set 500Ah battery capacity on the inverter). If your battery bank is very big, choose the maximum capacity value allowed by the inverter.

Please remember that you need to press CONFIRM  to record the new settings, and then **switch the inverter off and back on** for them to come into effect.

6. Troubleshooting and faults

This inverter is equipped with advanced self-testing and fault finding algorithms. If there are any faults found, the unit will indicate them by showing the red LED light, display the fault symbol  in the top left corner of the LCD display together with the fault code, and / or produce an alarm sound. The following table provides a summary of the fault codes and corresponding solutions.

Fault Code	Fault	Reason and Solution
01	High temperature - fan fault (alarm light on)	Inverter is too hot; ensure that the inverter is well ventilated, and not in direct sunlight. Check for any dust or debris that may have blocked the fans. Switch the inverter off and wait for 30 minutes. If the fan still doesn't work and the fault happens again, the fan will need replacing.
02	Overload (alarm light on)	Power drawn by the load is too high for the inverter. Reduce the number / power of your appliances to enable the inverter work.
03	Output short circuit (alarm light on)	Turn off the inverter, disconnect all loads. Check the connections or possible wiring problems. Check loads for short circuits, reconnect and turn on. If the problem persists, contact the manufacturer or supplier.
04	High temperature (alarm light on)	Inverter is too hot; ensure that the inverter is well ventilated, and not in direct sunlight. Switch the inverter off and wait for 30 minutes. If the problems persist, contact the manufacturer or supplier.
05	Low battery voltage (alarm light on)	Battery is discharged, or the load is too high for battery to hold voltage. Allow the battery to charge to full capacity without applying a load. If powerful loads are required, increase the battery capacity. Check the charger on a healthy batt.
06	Reverse input and output	Disconnect the input and output, check for any damage and swap them around.
07	Semi-wave short circuit (unusual load)	The load power required is too high for the inverter. Reduce the number and power of your appliances to enable the inverter to work.
08	Over charge	Charger damage. Contact the manufacturer or supplier.
09	Battery over voltage	Check if the battery bank voltage is appropriate for the inverter and reconfigure the batteries if needed.

7. Specifications

General specifications			
Input wave form:	Sine wave (utility or generator)		
Nominal voltage:	230VAC		
Low voltage trip:	125 - 174V \pm 4%		
Low voltage re engage:	135 - 194V \pm 4%		
High voltage trip:	263 - 273V \pm 4%		
High voltage re engage:	253 - 263V \pm 4%		
Max input AC voltage:	273V AC		
Nominal input frequency:	50Hz or 60Hz (auto detect)		
Low freq trip:	40Hz for 50Hz, 50Hz for 60Hz		
High freq trip:	55Hz for 50Hz, 65Hz for 60Hz		
Output wave form:	(Bypass mode) same as input		
Overload protection:	Circuit breaker		
Short circuit protection:	Circuit breaker		
Transfer switch rating:	30amp or 40amp		
Efficiency on line transfer mode:	95%		
Line transfer time:	10-20ms (typical 10ms)		
Max bypass current:	30amp or 40amp		
Bypass over load current:	35amp or 45amp: Alarm		
Inverter specification / output			
Output wave form:	Pure sine wave		
Output continuous power Watts:	2000W, 3000W, 6000W		
Power factor:	0.9-1.0		
Nominal output voltage rms:	120/230VAC		
Output voltage regulation:	10% RMS		
Output frequency:	50Hz \pm 0.3Hz or 60Hz \pm 0.3Hz		
Nominal efficiency:	>85%		
Surge ratings:	300% nominal power (6000W, 9000W, 18000W)		
Short circuit protection:	yes, fault after 10 secs		
Power saver threshold:	25W		
Inverter specification / input			
Nominal Input voltage:	12V	24V	48V
Minimum start voltage:	10V	20V	40V
Low battery alarm:	10.5V	21V	42V
Low battery trip:	10V	20V	40V
High voltage alarm:	16V	32V	64V
Charger specification			
Input voltage range:	155-263V AC		
Output voltage:	Dependent on battery type		
Charger current:	15A/20A/35A/50A/70A/90A (dep. on the model)		
Battery initial voltage for start up:	10-15.7V for 12V (*2 for 24V, *4 for 48V)		
Over charge protection shutdown:	15.7V for 12V (*2 for 24V, *4 for 48V)		
Mechanical parameters			
Size	2000W and 3000W models: 460*220*190mm 6000W model: 650*220*190mm		
Weight	2000W 20kg, 3000W 25.5kg, 6000W 48kg.		

*Appendix 1. Battery charging stages
(when the mains battery charger is On)*

Depending on your inverter model, it would have been supplied with 35A, 70A or 90A mains battery charger. This is the absolute maximum charging current – it is possible to reduce it in the inverter settings (see Setting section of the manual) to a lower value which will be the *operating charging current* (A). **Lower current is necessary for some battery types which can be damaged by fast charging.**

The chart below shows 4 different charging stages for your battery bank, with the red graph showing voltage (left axis) and the blue graph showing current (100% represents the *operating charging current* value). Please note that the voltage scale is provided for illustration purposes only – the actual battery charging voltage might be different depending on the inverter type (12V / 24V / 48V) and the selected battery type.

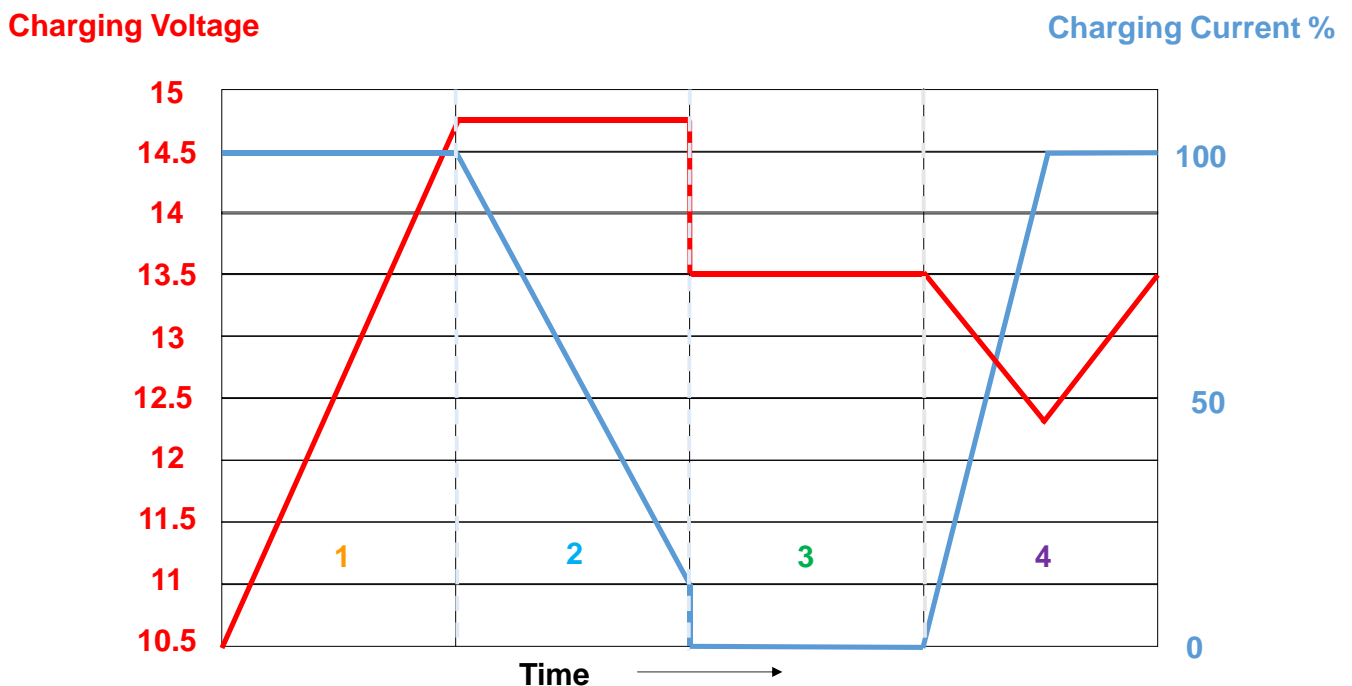

- 1. Constant current stage.**
- 2. Absorption stage at 14.4V to 14.8V.**
- 3. Constant voltage stage.**
- 4. Low voltage step to stage 1.**

1. Boost Constant Current (CC) Stage: if AC input is applied then the charger will run at full *operating charging current* in constant current (CC) mode until the charger reaches the boost voltage.
The software timer will measure the time from the start, until the battery charger reaches 0.3V below the boost voltage, it then takes this time as T0 and $T0+10=T1$
2. Boost Constant Voltage (CV) Stage: starts the T1 Timer; the charger will keep the boost voltage in boost constant voltage (CV) mode until the T1 Timer has run out, then drop the voltage down to the float voltage. The timer has a minimum time of 1 hour and a maximum time of 12 hours.
3. Float Stage: when in the float mode the voltage will stay at the float voltage set point.
4. If the AC is reconnected or the battery voltage drops below 12V DC, the charger will reset the cycle above. If the charger remains in the float stage for 10 days, the charger will reset the cycle.

The desulphation cycle is marked in red in the manual because this is a very dangerous setting. Before attempting to use this cycle, you need to have good understanding what it does, how and when to use it.

What causes sulphation?

This can occur with infrequent use of the batteries or if the batteries have been left discharged so low that they will not accept a charge.

What is a desulphation cycle?

This cycle is a very high voltage charging cycle designed to try to break down the sulphate “crust” that is preventing the battery plates from taking a charge, and thus allowing the plates to clean up and accept a charge once again.



Please note: this cycle is only suitable for open lead acid batteries.

How to use this cycle?

- Ensure that the battery bank is totally isolated from everything else; the high voltage applied by this setting could destroy all your electronics and other electrical equipment still connected to the batteries.
- Make sure the battery compartment is very well ventilated and battery caps are removed.
- Turn the inverter on, switch the battery type to the correct position, confirm and turn the inverter off. Then connect the AC power on to the inverter.
- Because this is such a dangerous feature there is a 4 hour time out period built into the programme. However, on a very large battery bank this may not be enough and the unit may need to be switched off and on again to do another cycle.
- Don't forget to change the battery type back to normal at the end of the cycle and turn the inverter Off / On for settings to take the effect.

What to expect on this cycle?

It is recommended that you monitor the voltage of the sulphated battery bank. When you switch on the cycle, the voltage should go to the full 15.5V very fast (within minutes). This is because the batteries cannot accept the charge (assuming they are sulphated). However, over a period of 1-2 hours the voltage should start to drop (as the plates start to clean and batteries start to take charge) the voltage could drop way down to about 12.5 volts, then start to rise. This shows that the batteries are now taking a charge and starting to fill up. In this case it would be safe to switch the unit off and select your normal battery type. You may need to repeat the process a few times.



This is a professional tool. Never leave the system unattended when using this mode. If the battery temperature reaches 50°C, or you come across any other irregularities, stop the process immediately.